

UL-C** Marine Shipboard Cable Glands featuring CROCLOCK® – ASSEMBLY INSTRUCTIONS

Brief Description

Peppers UL-C** Compound-filled cable glands featuring Croclock® are for outdoor use in the appropriate Hazardous Locations with Tray cable and Armoured Marine Shipboard cables (CEC and NEC applications), circular pliable wire, steel wire, steel tape armoured, braided, screened and unarmoured cable (IEC applications). They give environmental protection to IP66, IP68 & Type 4X.

Warning

Please read these instructions carefully. These products should not be used in applications except as detailed here or in our datasheets, unless confirmed in writing by Peppers. Peppers take no responsibility for any damage, injury or other consequential loss caused where products are not installed or used according to these instructions. This leaflet is not intended to advise on the selection of product. Further guidance can be found in the standards listed overleaf or the prevailing code of practice. The compound has application limitations and may be adversely affected by some solvent vapours. If such vapours are likely to be present when the cable gland is in service, necessary precautions should be taken. Peppers Technical Datasheet can be downloaded from our website for further guidance. The compound should be stored in its original packaging in a dry area at temperatures between 5°C and 21°C.

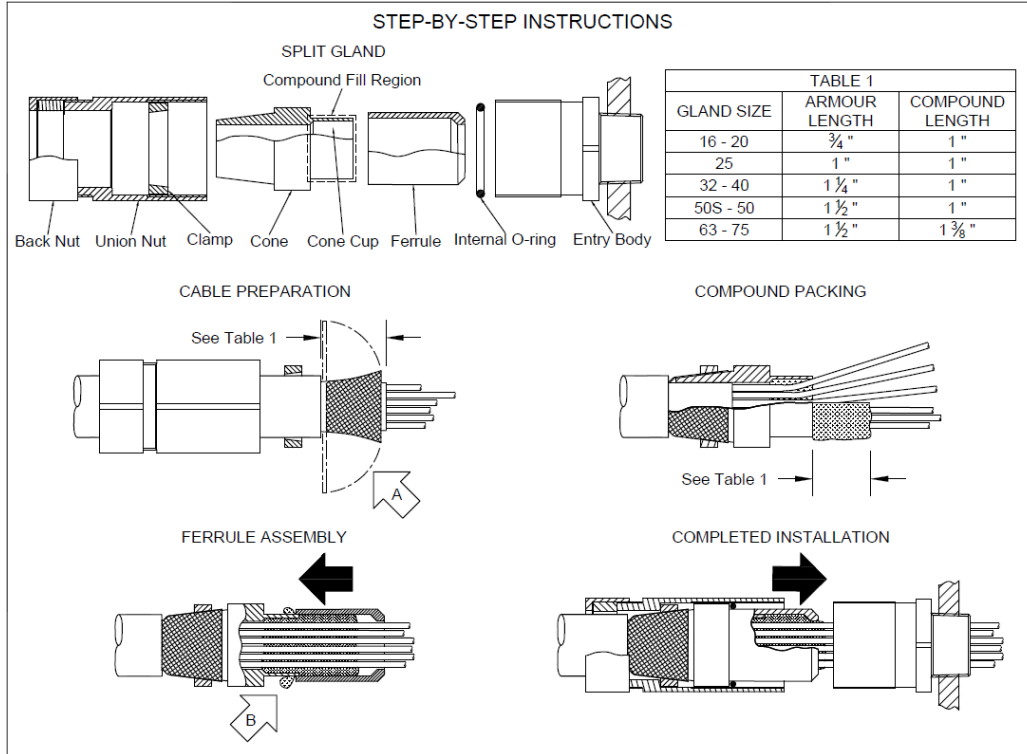

GLAND SIZE	ARMOUR LENGTH	COMPOUND LENGTH
16 - 20	¾"	1"
25	1"	1"
32 - 40	1 ¼"	1"
50S - 50	1 ½"	1"
63 - 75	1 ½"	1 ¾"

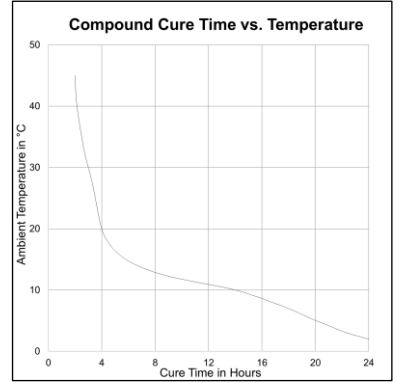

Figure 1



Figure 2



STEP BY STEP INSTRUCTIONS

1. Split gland as shown.
2. Fit Entry Body, allowing for any installation accessories, and fully engage the thread into the equipment. Hand-tighten, then suitably secure with a wrench. Further guidance can be found in Peppers document CT0030 which can be found on our website.
3. Slide Back Nut, Mid Cap and Clamp (Rear Assembly) and shroud if required onto cable as shown. Put Ferrule and Internal O-ring to one side.
4. CABLE PREPARATION
 - A. Strip off outer jacket, length to suit installation.
 - B. Cut armour. For approximate exposed lengths see Table 1.
 - C. Remove inner sheath. Remove protective foils, and any cords/fillers from around and between the cores level with the inner sheath. Take care not to cut the insulating sleeves of the cores. Using Listed sleeving, pigtail and sleeve screens to be passed through compound and Entry Body.
 - D. Tease out armour using a suitable tool (e.g. thin screwdriver) and splay out radially as shown (arrow A).
5. Slide Cone all the way back onto inner sheath. Press down armour around cone. Slide Clamp onto armour. Trim armour if required. Insert cable through Entry Body and engage Cone into Entry Body (Ferrule may be left off to aid Step 6).
6. To clamp armour onto Cone, hand-tighten Mid Cap to Entry Body, then using wrench tighten a further 1 turn. Cable with maximum diameter wire armour may require an additional ½ to 1 turn.
7. Unscrew Mid Cap to visually check armour is securely clamped. If armour has not clamped repeat the clamping process. Pull out cable and Cone.

HEALTH AND SAFETY WARNING: The resin used in the compound can cause eye and skin irritation. For your personal protection, wear the gloves supplied whilst in contact with the compound. **A COMPREHENSIVE SAFETY DATA SHEET IS AVAILABLE FOR DOWNLOAD FROM OUR WEBSITE.**

8. Check compound has not passed its "Use By" date. It has a work life of about 30 minutes at 16-27°C (60-80°F), during which time it can be worked and shaped before it begins to cure. Full cure takes 24 hours at 16-27°C (60-80°F). Lower temperatures will give a longer cure time. E.g. at 3°C (37°F) full cure takes about seven days. See Compound Cure Time Vs. Temperature. It is recommended to mix the putty and pack the fitting at 20°C (68°F). Minimum mixing/packing temperature is 10°C. Minimum curing temperature is 3°C.
9. Trim any hardened pieces from ends of stick. Mix the compound by rolling, folding and breaking. Ease mixing by cutting large sticks in half. Fully mixed compound has a uniform colour with no streaks, see Figure 1.
10. Support cable and Rear Assembly. Splay out cores. Starting in the middle, fill Cone Cup by packing small amounts of rolled-out compound around and between the cores. Re-straighten each core and work outwards until all gaps are filled. Pack around the outside of the outer cores. Push compound down to make sure the Cone Cup is filled.
11. Similarly build up compound in and around the protruding cores. Apply the compound in rolled-out strips wherever possible so that unbroken layers are formed. Where joins occur in the fill or there are suspected holes, work the compound together to ensure a gas-tight seal. The cylinder of compound should project approx. 1 in / 25mm (or 1 ½ in / 35mm for sizes 63 & 75 - see diagram). Retrieve Ferrule and pass it over cores. Locate and press Ferrule onto Cone and remove any squeezed-out compound (arrow B). Pass cores through Entry Body. Engage Ferrule in Entry Body and screw on Mid Cap. Tighten with wrench to close up the Ferrule Assembly.
12. Slacken off Mid Cap to inspect Cable Unit. Where the cores exit the Ferrule, projecting compound must not foul the Entry Body. Bundle cores with cable-tie, cord or tape so they are not disturbed, see Figure 2. Leave to cure. Cores may be disturbed after 1 hour.
13. Slide silicone O-ring over outer diameter of ferrule and ensure it is located at base of ferrule.
14. Re-assemble Cable Unit to Entry Body ensuring the O-ring is seated on the outside of the ferrule. Fully tighten Mid Cap using wrench. Hold Mid Cap with wrench and tighten Back Nut onto cable. Ensure jacket seal makes full contact with cable then tighten Back Nut 1 extra turn.

Gland Trade Size, Cable Size (imperial & metric) and Construction

Gland Size	Standard Trade Size		Max. Number of Cores by Approval		Maximum Diameter Over Cores		Inner Sheath		Outer Jacket Diameter						Armour Size, mm			
									Standard			Reduced Bore						
	NPT	Metric	UL	Other	inch	mm	Min.	Max.	Min.	Max.	Min.	Max.	Min.	Max.				
16	½" & ¾"	M20 & M25	1	15	0.409	10.4	0.461	11.6	0.362	8.4	0.531	13.5	0.264	6.7	0.406	10.3	0.15	1.25
20S	½" & ¾"	M20 & M25	4	35	0.409	10.4	0.461	11.6	0.453	11.5	0.630	16.0	0.370	9.4	0.492	12.5	0.15	1.25
20	½" & ¾"	M20 & M25	8	40	0.492	12.5	0.551	14.0	0.610	15.5	0.831	21.1	0.563	14.3	0.693	17.6	0.15	1.25

UL-C** Marine Shipboard Cable Glands featuring CROCKLOCK® – ASSEMBLY INSTRUCTIONS

Gland Size	Standard Trade Size		Max. Number of Cores by Approval		Maximum Diameter Over Cores		Inner Sheath		Outer Jacket Diameter								Armour Size, mm	
									Standard				Reduced Bore					
									Min.		Max.		Min.		Max.			
25	3/4" & 1"	M25 & M32	16	60	0.701	17.8	0.787	20.0	0.799	20.3	1.079	27.4	0.689	17.5	0.941	23.9	0.15	1.6
32	1" & 1 1/4"	M32 & M40	30	80	0.925	23.5	1.035	26.3	1.051	26.7	1.339	34.0	0.984	25.0	1.201	30.5	0.15	2.0
40	1 1/4" & 1 1/2"	M40 & M50	60	130	1.134	28.8	1.267	32.2	1.299	33.0	1.598	40.6	1.154	29.3	1.425	36.2	0.2	2.0
50S	2"	M50 & M63	5	200	1.374	34.9	1.503	38.2	1.551	39.4	1.839	46.7	1.499	38.1	1.669	42.4	0.2	2.5
50	2"	M50 & M63	5	400	1.551	39.4	1.736	44.1	1.799	45.7	2.094	53.2	1.618	41.0	1.909	48.5	0.2	2.5
63S	2 1/2"	M63 & M75	4	400	1.764	44.8	1.972	50.1	2.051	52.1	2.343	59.5	1.846	46.9	2.157	54.8	0.3	2.5
63	2 1/2"	M63 & M75	4	425	1.969	50	2.204	56.0	2.299	58.4	2.591	65.8	2.118	53.8	2.409	61.2	0.3	2.5
75S	3"	M75	4	425	2.181	55.4	2.440	62.0	2.551	64.8	2.843	72.2	2.469	62.7	2.677	67.7	0.3	2.5
75	3"	M75	4	425	2.394	60.8	2.677	68.0	2.799	71.1	3.071	78.0	2.618	66.5	2.890	73.4	0.3	2.5

Approvals and Certification

Approval	Certificate Number	Protection Concept / Type
ATEX (2014/34/EU)	CML 19ATEX1349X / CML 21UKEX1028X	(Ex) I M2 II 1D 2G Ex db I Mb / Ex db IIC Gb / Ex eb I Mb / Ex eb IIC Gb / Ex ta IIC Da
UKCA (SI 2016 No. 1107)	CML 19ATEX4114X / CML 21UKEX4037X	(Ex) II 3G Ex nR IIC Gc
IECEX	IECEX CML 19.0107X	Ex db I Mb / Ex db IIC Gb / Ex eb I Mb / Ex eb IIC Gb / Ex nR IIC Gc / Ex ta IIC Da
UL	E248936	Class I Div 1 Gas Groups A, B, C & D Type 4X
CSA	70004604	Class I, Div. 1, Groups A, B, C and D; Class II, Div. 1, Groups E, F and G; Class III; Type 4X * Class I, Div. 2, Groups A, B, C and D; Class II, Div. 1, Groups E, F and G; Class III; Type 4X Ex db IIC Gb / Ex eb IIC Gb / Ex ta IIC Da (Canada) Class I Zone 1 AEx db IIC Gb / AEx eb IIC Gb Type 4X / Class II, Zone 20 AEx ta IIC Da (USA)
INMETRO	NCC 13.1957 X	Ex db I Mb / Ex db IIC Gb / Ex eb I Mb / Ex eb IIC Gb / Ex nR IIC Gc / Ex ta IIC Da
EAC	ПРОММАШ ТЕСТ РУ C-GB.АЖ58.В.05106	PB Ex db I Mb / 1Ex db IIC Gb X / PB Ex eb I Mb X / 1Ex eb IIC Gb X / 2Ex nR IIC Gc X / Ex ta IIC Da X
UKRAINE	CU 18.0324 X	I M2 Ex db I Mb / Ex eb I Mb / II 1D 2G 3G Ex db IIC Gb / Ex eb IIC Gb / Ex nR IIC Gc / Ex ta IIC Da
CCC	2021312313000425	Ex db I Mb / Ex db IIC Gb / Ex eb I Mb / Ex eb IIC Gb / Ex nR IIC Gc / Ex ta IIC Da IP66
CCoE (PESO)	P494321/9 & P494321/20	Ex db I Mb / Ex db IIC Gb / Ex eb I Mb / Ex eb IIC Gb / Ex nR IIC Gc
ECASEx	25-06-153223/E25-06-159811/NB0007	Ex db I Mb / Ex db IIC Gb / Ex eb I Mb / Ex eb IIC Gb / Ex nR IIC Gc / Ex ta IIC Da
ABS	25-0158110-PDA	Specified ABS Rules – See certificate
Lloyd's Register	LR25189453TA	Ex db I Mb / Ex db IIC Gb / Ex eb I Mb / Ex eb IIC Gb / Ex nR IIC Gc / Ex ta IIC Da
DNV	TAE00004XK	Ex db I Mb / Ex db IIC Gb / Ex eb I Mb / Ex eb IIC Gb / Ex nR IIC Gc / Ex ta IIC Da

* Class I, Div. 1 applications for offshore installations utilising Marine Shipboard Cable where permitted by the relevant code.

Installation Advice

Point	Advice
1	BS/EN/IEC 60079-10 BS/EN/IEC 60079-14 National Electrical Code (NEC 500-505) Canadian Electrical Code (CSA C22.1)
2	CEC and NEC Offshore/Marine Shipboard Applications: For Class I Division 1 Group ABCD Installations this product is intended for Marine Shipboard cables and installed according to the prevailing Electric Code, US Coast Guard Electrical Engineering Regulations & Ship Safety Electrical Standards.
3	Comprehensive details of the compliance standards can be found on the product certificates which are available for download from our website
4	Installation should only be carried out by a competent electrician, skilled in cable gland installation.
5	NO INSTALLATION SHOULD BE CARRIED OUT UNDER LIVE CONDITIONS.
6	Threaded entries: the product can be installed directly into threaded entries. Threaded entries should comply with the relevant applicable standards and have a lead-in chamfer to allow for full engagement of the threads. Failure to provide a sufficient lead-in chamfer may lead to ingress sealing issues. For Ex db applications a minimum of 5 fully engaged threads is required.
7	Clearance holes: these shall be no larger than 0.7mm above the nominal diameter of the external entry thread. The product should be secured with a Peppers locknut and then tightened to ensure the cable gland is secure. Where no integral sealing method is provided a Peppers sealing washer should be used to maintain IP ratings. A Peppers serrated washer should be used for additional installation protection. Peppers does not recommend using tapered threads in clearance holes.
8	Ingress protection: to maintain the Ingress Protection rating of the product, entry holes must be perpendicular to the surface of the enclosure. The surface should be clean, dry and must be sufficiently flat and rigid to support the assembly and make the IP joint. Metric threads are supplied with an O-ring and will maintain IP66 and IP68. Other parallel threads will maintain an IP rating of IP64. A Peppers sealing washer should be used to maintain all IP ratings greater than IP64. Whilst Peppers products with tapered threads, when installed into a threaded entry, have been tested to maintain IP66 without any additional sealant, due to the differing gauging tolerances associated with the use of tapered threads it is recommended to use a non-hardening thread sealant if an IP rating higher than IP64 is required. Any thread sealant used should be suitable for use in the hazardous area or location where the equipment is installed, have a suitable temperature range for the temperature at the point of mounting, not contain evaporating solvents and not cause corrosion at the threaded interface when used with dissimilar materials. The product incorporates a thread run out according to general machining techniques and will not have a full form thread for the entire length. Threaded entries should have a suitable lead-in chamfer to ensure a seal is maintained, further guidance can be found on Peppers website. It is the user's/installer's responsibility to ensure that the interface between the enclosure and cable gland is suitably sealed for the required application.
9	Where a bonding connection to earth is required a Peppers earth tag should be used. Peppers earth tags have been independently tested to comply with the Category B values given in IEC 62444. Peppers earth tags should be fitted over the external entry thread from either inside or outside the enclosure. If fitted internally they must be secured with a Peppers locknut and optionally a Peppers serrated washer. Further guidance can be found in Peppers document CT0170 which can be found on our website.
10	Peppers external metric entry threads comply with ISO 965-1 & ISO 965-3 with a 6g tolerance fit. The standard metric thread pitch is 1.5mm for threads up to M75 and 2.0mm for size M80 and above. Alternative thread pitches are available upon request. Peppers external NPT threads comply with ASME B1.20.1 with gauging to clause 8.1. All threads comply with the threaded joint requirements of clause 5.3 from IEC 60079-1. Information on other thread types can be found in the product certificates.
11	Once installed do not dismantle except for routine inspection. An inspection should be conducted as per IEC 60079-17. After inspection the gland should be re-assembled as instructed, ensuring the compression nut, mid cap and back nut are correctly tightened to ensure the cable is secure.
12	Environmental and ingress protection may be reduced when using unjacketed cable
13	If required an anti-seize lubricant may be used to aid assembly of gland threads. The lubricant should comply with the prevailing code of practice and care should be taken to ensure no lubricant comes into contact with the cable gland seals as this may impair performance.

Approved Temperature Range

UL Approval	All Other Approvals
-25°C to +85°C / -13°F to +185°F	-60°C to +135°C / -76°F to +275°F

Environmental Protection

UL Approval	CSA Approval	All Other Approvals
Type 4X / Raintight	IP66 / IP68 (100 metres for 7 days) / Type 4X Oil resistant II	IP66 / IP68 (100 metres for 7 days)

Interpretation of Markings

Markings on the outside of this gland carry the following meanings: UL-C-a-R-bbb-ccc-nn

UL =	Barrier gland product range	bbb =	Gland size
C =	Crocklock® universal clamping ring incorporating an epoxy resin compound	ccc =	Entry thread type and size
a =	Main component material	R =	Optional reduced bore jacket seal (red)
	B = Brass	nn =	Year of manufacture
	S = Stainless steel		

Specific Conditions of Use

- UL-C** glands must not be used in enclosures where the temperature at the point of contact is outside the range of -25°C to +85°C for UL applications or -60°C to +135°C for other (IEC based) applications.
- The interface seals comply with the requirements of the standards listed the certificates above when UL-C** glands are fitted to a representative enclosure having a smooth flat mounting surface. In practice the interface between the male thread of the glands and their associated enclosure cannot be defined, therefore it is the user's responsibility to ensure that the appropriate ingress protection level is maintained at these interfaces.
- UL-C** glands with parallel threaded entry components shall be suitably sealed using a method that is suitable for the associated equipment, in accordance with the relevant installation code of practice such that any ingress protection and restricted breathing sealing requirements are maintained.
- When used in explosive dust atmospheres and installed in threaded entries without interface O-ring seals, UL-C** glands shall only be fitted into enclosures that have either:
 - parallel entries that will ensure a minimum of 5 full threads of contact will be maintained, this is in accordance with clause 5.1.2 of IEC 60079-31.
 - tapered entries that will ensure a minimum of 3 1/2 full threads of contact will be maintained, this is in accordance with clause 5.1.2 of IEC 60079-31.
- UL-C** glands are manufactured with a cylindrical flameproof joint between the entry body and the front ferrule. This joint is not intended for repair.

