

RAFF, RAFF90, RAMF, RAMF90, RAMM, RAMM90 Range – Rotating Adaptors & Reducers / Unions – INSTALLATION INSTRUCTIONS

Warning

PLEASE STUDY THESE INSTRUCTIONS CAREFULLY BEFORE INSTALLATION. These products should not be used in any application other than those mentioned here or in our Data Sheets, unless Peppers states in writing that the product is suitable for such application. Peppers can take no responsibility for any damage, injury or other consequential loss caused where the products are not installed or used according to these instructions. This leaflet is not intended to give advice on the selection of the products. Further guidance can be found in the standards listed overleaf or the prevailing code of practice.

Brief Description

Peppers RA range of Rotating Adaptors and Reducers are intended for indoor or outdoor use in the appropriate hazardous area locations. Rotating Adaptors and Reducers are designed to facilitate the installation of an entry device into an enclosure or housing. They may also be used where the entry threads on the equipment are dissimilar. They give environmental protection to IP66 and IP68 and are suitable for both mining and surface applications.

Installation

All Peppers Rotating Adaptors and Reducers should be installed and tightened to ensure the appropriate IP rating of the installation is maintained. Further guidance can be found in Peppers document CT0030 which can be found on our website. It is the users/installers responsibility to ensure that the interface between the enclosure and cable gland is suitably sealed for the required application.

Rotating Adaptors

1. The product should be hand-tightened and then suitably secured with a wrench ① according to the torque figures stated in Table 1. For threaded entries the entry thread ② should be fully engaged prior to tightening. For clearance hole applications the product should be secured with a locknut and, if required, a serrated washer.
2. Hand-tighten mating equipment ③ to connection thread by rotating back nut ④ with wrench and tighten.
3. Complete wiring and ensure installation is secure.

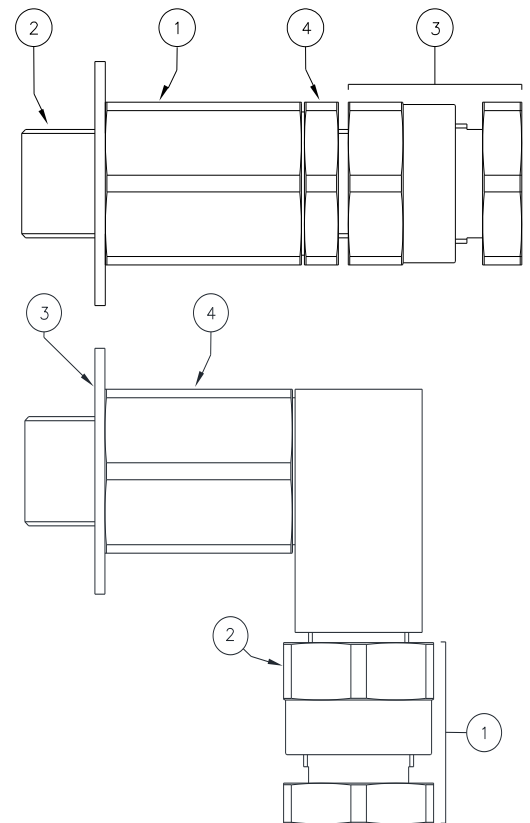

90° Rotating Adaptors

1. Assemble in reverse. Hand tighten connection thread to mating equipment ① and tighten with a wrench ②.
2. Thread product into enclosure ③. The product should be hand-tightened and then suitably secured with a wrench ④ according to the torque figures stated in Table 1. For threaded entries the entry thread should be fully engaged prior to tightening. For clearance hole applications the product should be secured with a locknut and, if required, a serrated washer.
3. Align equipment into required orientation, complete wiring and ensure installation is secure.

Installation Guidance

Point	Advice
1	BS/EN/IEC 60079-10 BS/EN/IEC 60079-14 National Electrical Code (NEC 500 – 505) Canadian Electrical Code (CSA C22.1)
2	Installation should only be carried out by a competent electrician, skilled in cable gland installation.
3	Comprehensive details of the compliance standards can be found on the product certificates which are available for download from our website.
4	NO INSTALLATION SHOULD BE CARRIED OUT UNDER LIVE CONDITIONS.
5	Threaded entries: the product can be installed directly into threaded entries. Threaded entries should comply with the relevant applicable standards and have a lead-in chamfer to allow for full engagement of the threads. Failure to provide a sufficient lead-in chamfer may lead to ingress sealing issues. For Ex db applications a minimum of 5 fully engaged parallel threads is required. Any thread sealant used should be non-hardening. Whilst Peppers products with tapered threads, when installed into a threaded entry, have been tested to maintain IP66 without any additional sealant, due to the differing gauging tolerances associated with the use of tapered threads it is recommended to use a non-hardening thread sealant if an IP rating higher than IP64 is required.
6	Clearance holes: these shall be no larger than 0.7mm above the nominal diameter of the external entry thread. The product should be secured with a Peppers locknut and the threads tightened to ensure the installation is secure. A sealing washer shall be used to maintain IP ratings. A serrated washer should be used for additional installation protection.
7	To maintain the Ingress Protection rating of the product, the entry hole must be perpendicular to the surface of the enclosure. The surface should be sufficiently flat and rigid to support the assembly and make the IP joint. The surface must be clean and dry. The product incorporates a thread run out according to general machining techniques and will not have a full form thread for the entire length and as such entry threads should have a suitable lead-in chamfer to ensure a seal is maintained. Further guidance can be found on Peppers website. It is the users/installers responsibility to ensure that the interfaces and threads between the enclosure and adaptor/reducer and the associated cable gland/entry device is suitably sealed with O-rings, sealing washers and/or with thread sealant for the required application. Any thread sealant used shall be suitable for use in hazardous area locations, be suitable for the temperature range at the point of mounting, shall not contain evaporating solvent and cannot cause corrosion at the threaded interface when used for dissimilar materials.
8	Where a bonding connection to earth is required a Peppers earth tag should be used. Peppers earth tags have been independently tested to comply with the Category B values given in IEC 62444. Further guidance can be found on Peppers website. Peppers earth tags should be fitted over the external entry thread from either inside or outside the enclosure. If fitted internally they must be secured with a Peppers locknut and optionally a Peppers serrated washer.
9	Restricted Breathing Requirements: - Adaptors and Reducers with parallel threads and fitted with appropriate sealing rings provide a restricted breathing seal. Adaptors and Reducers with tapered or parallel threads, installed into unthreaded entry holes, secured with a locknut, and fitted with appropriate sealing rings provide a restricted breathing seal.
10	The product is not intended to be dismantled. Once installed the product should fall under routine inspection as per IEC/EN 60079-17.
11	If required an anti-seize lubricant may be used to aid assembly and routine inspection. The lubricant should comply with the prevailing code of practice and care should be taken to ensure no lubricant comes into contact with the products seals or flamepaths as this may impair performance.

Product Ingress Protection / Enclosures Ratings

When installed in accordance with these instructions the Peppers

RA range will maintain the following IP ratings: -

Male Thread Type	Seal Type	IP Rating	Torque
Parallel	No Seal	IP64	Wrench Tight
Parallel	Sealing Washer	IP66 / IP68	See Table 1
Tapered	No Seal	IP66	Wrench Tight
Tapered	Thread Sealant	IP66 / IP68	Wrench Tight
IP68 – Products tested to a depth of 2 metres for a period of 24 hours			

Note: Torques are for Nylon and Fibre Washers.

For other materials please refer to our website.

Table 1 – Installation Torques

Male Metric Thread (and equivalent thread forms)	Torque (Nm)
M12, M16, M20	25
M25, M32	45
M40	50
M50	70
M63	110
M75	200
M80, M85, M90, M100	250

Limitations on Usage

Be sure your installation complies with the following:-

Feature	Comment
Temperature Limitations	Products are approved for a temperature range at their point of mounting based upon the interface seal as detailed below: -
	Seal Material
	No Seal
	Fibre Washer
	Nylon Washer
	Temperature Range
	-60°C to +135°C
	-40°C to +95°C
	-40°C to +135°C
	-60°C to +135°C
CSA Approval	Adaptors and Reducers shall not be used in any application where the operating temperature is below -50°C. Class I conduit applications, for products with a female connection thread, the female thread must be NPT RA** Adaptors and Reducers are not intended for use with metallic cable applications.

Interpretation of Markings. Markings on the outside of this product carry the following meanings:

Adaptor Type & Size: RAMF-aaa-bbb where aaa and bbb is the respective male and/or female thread size of the Adaptor

Approvals

Approval	Certificate Number	Protection Concept / Type
ATEX (2014/34/EU)	CML 19ATEX1330X / CML 21UKEX1026X	Ⓔ I M2 II 1D 2G Ex db I Mb / Ex db IIC Gb / Ex eb I Mb / Ex eb IIC Gb / Ex ta IIIC Da
UKCA (SI 2016 No. 1107)	CML 19ATEX4331X / CML 21UKEX4027X	Ⓔ II 3G Ex nR IIC Gc
IECEX	IECEX CML 19.0101X	Ex db I Mb / Ex db IIC Gb / Ex eb I Mb / Ex eb IIC Gb / Ex nR IIC Gc / Ex ta IIIC Da
CSA - Canada	2310046	Ex db IIC Gb / Ex eb IIC Gb Ex ta IIIC Da Type 4X / 6P
CSA - US	2310046	Class I Zone 1 AEx db IIC Gb / AEx eb IIC Gb Zone 20 AEx ta IIIC Da Type 4X / 6P
CCC	2021312313000376	Ex db I Mb / Ex db IIC Gb / Ex eb I Mb / Ex eb IIC Gb / Ex nR IIC Gc / Ex ta IIIC Da
CCoE / PESO	P494321/14 & P494321/14	Ex db I Mb / Ex db IIC Gb / Ex eb I Mb / Ex eb IIC Gb / Ex nR IIC Gc
ABS	20-LD1944057-PDA	Specified ABS Rules – See certificate
Lloyds Register	LR2124442TA	Ex d I Mb / Ex d IIC Gb / Ex e I Mb / Ex e IIC Gb / Ex nR IIC Gc / Ex tD A20 IP66 / IP68

Conditions for Safe Use

1. The Adaptors, Reducers and Elbows are manufactured with a cylindrical joint between the entry body and threaded ferrule. This joint shall not be repaired.
2. The Adaptors, Reducers and Elbows shall not be used outside their service temperature range of -60°C to +135°C.
3. The Adaptors, Reducers and Elbows, when used in Group I (mining) applications, shall be mounted in a location with low risk of mechanical damage.