

EC1-U** Eclipse Compound-Filled Cable Gland – ASSEMBLY INSTRUCTIONS

Brief Description

The Peppers EC1-U** type Compound-filled cable gland is for outdoor use in the appropriate Hazardous Areas with unarmoured cable of any construction, with or without braids or screens, where the braids or screens pass through the compound. A variant giving electrical continuity to a lead sheath is available. It gives environmental protection to IP66, IP68 (100 metres for 7 days), IP69 and Deluge.

Warning

Please read these instructions carefully. These products should not be used in applications except as detailed here or in our datasheets, unless confirmed in writing by Peppers. Peppers take no responsibility for any damage, injury or other consequential loss caused where products are not installed or used according to these instructions. This leaflet is not intended to advise on the selection of product. Further guidance can be found in the standards listed overleaf or the prevailing code of practice. The compound used within this cable gland has application limitations and may be adversely affected by some solvent vapours. If such vapours are likely to be present when the cable gland is in service, necessary precautions should be taken. Peppers Technical Datasheet can be downloaded from our website for further guidance. Prior to use the compound should be stored in its original packaging in a dry area at temperatures between 5°C and 21°C.

STEP-BY-STEP FITTING INSTRUCTIONS

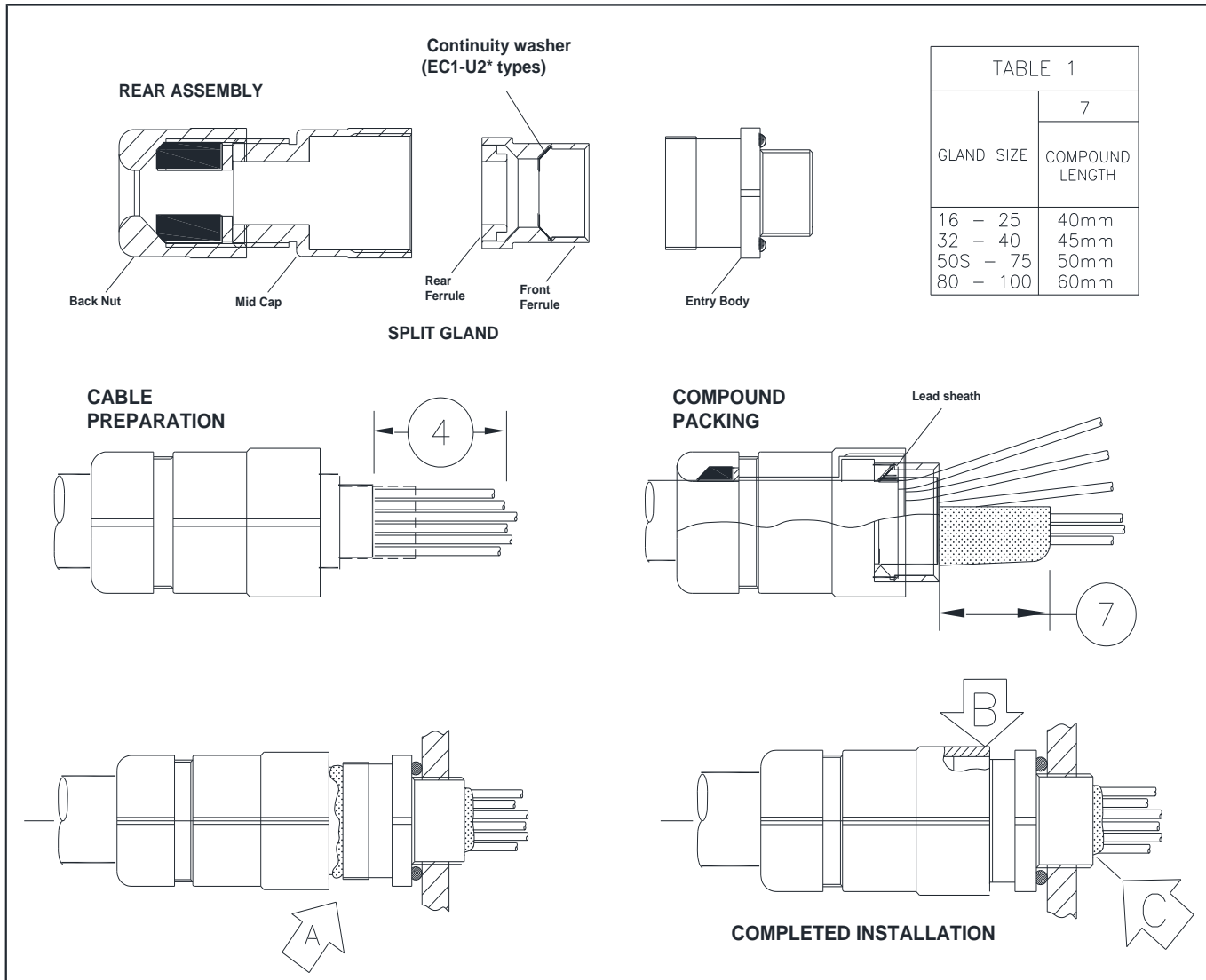

STEP-BY-STEP FITTING INSTRUCTIONS

- Split gland as shown. Warning. The entry body of this cable gland is coated with a releasing agent to ensure the compound form can be inspected after curing. The entry body should not be treated with any lubricant or be exposed to any solvents. The internal bore of the entry body must not be damaged. Any handling during the course of normal installation will not affect the operation of the releasing agent.
- Fit Entry Body, allowing for any installation accessories, and fully engage the thread into the equipment. For Entry Body installation torque for O-rings please refer to Table 2. Tapered threads shall be made up wrench tight. Further guidance can be found in Peppers document CT0030 which can be found on our website.
- Slide Rear Assembly (Back Nut, Mid Cap and Union Nut) onto cable as shown.
- CABLE PREPARATION**
Strip jacket so that cores are fully exposed in the compound chamber, length to suit installation. Lead sheath must be cut to push through the continuity washer. Remove protective foils, and any cords/fillers from around and between the cores. Take care not to cut the insulating sleeves of the cores. Pigtail and sleeve any screens to be passed through compound.

HEALTH AND SAFETY WARNING The compound can cause eye and skin irritation. For your personal protection, wear the gloves supplied whilst in contact with the compound. **A COMPREHENSIVE SAFETY DATA SHEET IS AVAILABLE FOR DOWNLOAD FROM OUR WEBSITE.**

- Check compound has not passed its "Use By" date. It has a work life of about 30 minutes at 16-27°C (60-80°F), during which time it can be worked and shaped before it begins to cure. Full cure takes 24 hours at 16-27°C (60-80°F). Lower temperatures will give a longer cure time. E.g. at 3°C (37°F) full cure takes about seven days. It is recommended to mix the putty and pack the fitting at 20°C (68°F). Minimum mixing/packing temperature is 10°C. Minimum curing temperature is 3°C.
- Trim any hardened pieces from ends of stick. Mix the compound by rolling, folding and breaking. Ease mixing by cutting large sticks in half. Fully mixed compound has a uniform yellow colour with no streaks See Figure 1 for correctly mixed compound.
- Support the cable and Rear Assembly, holding them roughly concentric. It may be necessary, particularly on small cable, to tighten the back nut to centralise the cable with the outer sheath seal. Any lead sheath should be pushed through the continuity washer - ensure that contact has been made. Splay out the cores. Starting at the middle, pack small amounts of rolled-out compound between the cores. Re-straighten each core and work outwards until all gaps are filled. Bundle the cores with cord or tape (see figure 2) so they are not disturbed. Pack around the outside of the outer cores to completely fill the Rear Assembly cup. Build up compound around the outside of the cores, with a slight taper & to approximate compound length shown in diagram & Table 1 column 7. Where cable has large quantity of cores ensure they are bundled near to the gland entry thread.
- Pass cores through & push compound into Entry Body until Rear Assembly engages. Remove squeezed out compound at arrow A. Screw Union Nut 7 full turns onto Entry Body (arrow B). Ensure that compound emerges at entry thread (arrow C).
- Clean off excess compound from Entry Body to allow withdrawal when cured (arrow C). Cores may be disturbed after 1 hour. Leave to cure for 4 hours when working at 21° C.
- To release and pull back joint for inspection, unscrew the Union Nut. Using a wrench on the Mid Cap, rotate the Mid Cap back and forth whilst pulling the rear assembly away from the entry body. This will release the compound from the entry body. Do not over rotate as this may damage cable conductors. Pull the Mid Cap and compound out for inspection. The compound should appear as in Figure 3 with no gaps, holes or cracks.

EC1-U** Eclipse Compound-Filled Cable Gland – ASSEMBLY INSTRUCTIONS

- 11 Hand-tighten Union Nut to remake joint. Then refer to Table 2 and tighten Union Nut using wrench to the given amount.
- 12 Hold Mid Cap with wrench and tighten Back Nut onto cable. Ensure seal makes full contact with cable sheath, then tighten 1 extra turn.
- 13 The equipment should not be energised until the compound has been left to cure for at least 4 hours when working at 21° C. See chart 'Energising Time vs. Temperature' for further guidance.

Figure 1



Figure 2

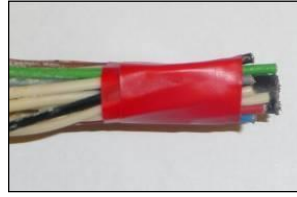
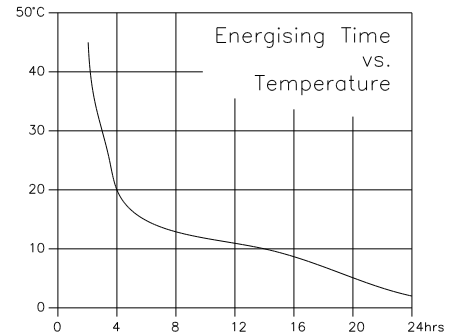

Figure 3



Table 2. Tightening information (Point 11), cable sizes (mm) and permitted cores

Gland Size	Entry Body Tightening Torque Point 2	Tighten Union Nut using wrench up to	Max Ø over Cores	Max No of Cores	Outer Sheath	
					Min	Max
16S	5Nm	½-turn	8.9	12	3.4	8.4
16	5Nm	½-turn	10.4	15	3.4	8.4
20S	5Nm	½-turn	10.4	35	4.8	11.7
20	5Nm	½-turn	12.5	40	9.5	14.0
25	5Nm	½-turn	16.5	60	11.7	18.5
32	10Nm	½-turn	23.5	80	18.1	26.3
40	10Nm	½-turn	28.8	130	22.6	32.2
50S	10Nm	½-turn	34.2	200	28.2	38.2
50	10Nm	½-turn	39.4	400	33.1	44.1
63S	10Nm	½-turn	44.8	400	39.3	50.1
63	10Nm	½-turn	50.0	425	46.7	56.0
75S	25Nm	½-turn	55.4	425	52.3	62.0
75	25Nm	½-turn	60.8	425	58.0	68.0
80	30Nm	¾-turn	64.4	425	61.9	72.0
85	40Nm	¾-turn	69.8	425	69.1	78.0
90	40Nm	¾-turn	75.1	425	74.1	84.0
100	40Nm	¾-turn	80.5	425	81.8	90.0



Approvals and Certification

Approval	Certificate Number	Protection Concept / Type
ATEX	CML 19ATEX1113X / CML 21UKEX1036X	Ex I M2 II 1D 2G Ex db I Mb / Ex db IIC Gb / Ex eb I Mb / Ex eb IIC Gb / Ex ta IIIC Da
UKCA (SI 2016 No. 1107)	CML 19ATEX4114X / CML 21UKEX4037X	Ex II 3G Ex nR IIC Gc
IECEX	IECEX CML 19.0035X	Ex db I Mb / Ex db IIC Gb / Ex eb I Mb / Ex eb IIC Gb / Ex ta IIIC Da / Ex nR IIC Gc
CCC	2021312313000446	Ex d I Mb / Ex d IIC Gb / Ex e I Mb / Ex e IIC Gb / Ex nR IIC Gc / Ex tD A20 IP66
CCoE / PESO	P494321/17 & P494321/20	Ex db I Mb / Ex db IIC Gb / Ex eb I Mb / Ex eb IIC Gb / Ex nR IIC Gc
Lloyd's Register	LR2124442TA	Ex db I Mb / Ex db IIC Gb / Ex eb I Mb / Ex eb IIC Gb / Ex ta IIIC Da / Ex nR IIC Gc

Installation Guidance

Point	Advice
1	EN/IEC 60079-10 EN/IEC 60079-14
2	Installation should only be carried out by a competent electrician, skilled in cable gland installation.
3	Comprehensive details of the compliance standards can be found on the product certificates which are available for download from our website
4	NO INSTALLATION SHOULD BE CARRIED OUT UNDER LIVE CONDITIONS.
5	Threaded entries: the product can be installed directly into threaded entries. Threaded entries should comply with the relevant applicable standards and have a lead-in chamfer to allow for full engagement of the threads. Failure to provide a sufficient lead-in chamfer may lead to ingress sealing issues. For Ex db applications a minimum of 5 fully engaged parallel threads is required. Metric threads are supplied with an o-ring and will maintain IP66 and IP68. Other parallel entry threads will maintain an IP rating of IP64. A Peppers sealing washer should be used to maintain all IP ratings greater than IP64. Whilst Peppers products with tapered threads, when installed into a threaded entry, have been tested to maintain IP66 without any additional sealant, due to the differing gauging tolerances associated with the use of tapered threads it is recommended to use a non-hardening thread sealant if an IP rating higher than IP64 is required.
6	To maintain the Ingress Protection rating of the product, the entry hole must be perpendicular to the surface of the enclosure. The surface should be sufficiently flat and rigid to support the assembly and make the IP joint. The surface must be clean and dry. The product incorporates a thread run out according to general machining techniques and will not have a full form thread for the entire length and as such entry threads should have a suitable lead-in chamfer to ensure a seal is maintained. Further guidance can be found on Peppers website. It is the user's/installer's responsibility to ensure that the interface between the enclosure and cable gland is suitably sealed for the required application. Any thread sealant used shall be suitable for use in hazardous area locations, be suitable for the temperature range at the point of mounting, shall not contain evaporating solvent and cannot cause corrosion at the threaded interface when used for dissimilar materials.
7	Where a bonding connection to earth is required a Peppers earth tag should be used. Peppers earth tags have been independently tested to comply with the Category B values given in IEC 62444. Further guidance can be found on Peppers website. Peppers earth tags should be fitted over the external entry thread from either inside or outside the enclosure. If fitted internally they must be secured with a Peppers locknut and optionally a Peppers serrated washer.
8	Peppers external metric entry threads comply with ISO 965-1 and ISO 965-3 with a 6g tolerance fit. Peppers standard metric thread pitch is 1.5mm for threads up to M75 and 2.0mm for size M80 and above. Alternative thread pitches are available upon request. Peppers external NPT threads are in accordance with ASME B1.20.1 with gauging to clause 8.1. All threads comply with the threaded joint requirements of clause 5.3 from IEC 60079-1. Information on other thread types can be found in the product certificates.
9	Once installed do not dismantle except for routine inspection. An inspection should be conducted as per IEC/EN 60079-17. After inspection the gland should be re-assembled as instructed, ensuring the mid cap and back nut are correctly tightened to ensure the cable is secure.
10	The o-ring that is fitted to the outer diameter of the Ferrule (visible on figure 2) is to prevent compound from travelling inside the gland during the assembly process. It has no other function and does not contribute to the protection concept or ingress protection rating of the cable gland.
11	If required an anti-seize lubricant may be used to aid assembly and routine inspection. The lubricant should comply with the prevailing code of practice and care should be taken to ensure no lubricant comes into contact with the cable gland seals as this may impair performance.
12	For chemical resistance information please refer to Peppers T1000 Compound data sheet. Available on request.

Interpretation of Markings. Markings on the outside of this gland carry the following meanings:

Cable Gland Type & Size EC1-U-2-a-bbb-ccc-nn; where: -

2 =	Optional Continuity Washer option for lead sheathed cable	bbb =	Gland size	nn =	Year of manufacture
a =	Main component material B = brass S = stainless steel	ccc =	Entry thread type and size		

Special Conditions for Safe Use

1. The cable glands/stopper boxes shall not be used in enclosures where the temperature, at the point of entry/mounting, is outside of the range of -60°C to +135°C for Peppers T1000 Compound.
2. The interface seals comply with the requirements of the standards listed in this report when the cable glands are fitted to a representative enclosure having a smooth flat mounting surface. In practice the interface between the male thread of the glands and their associated enclosure cannot be defined, therefore it is the users' responsibility to ensure that the appropriate ingress protection level is maintained at these interfaces.
3. The parallel threaded entry component threads will be suitably sealed using a method that is applicable to the associated equipment to which the gland will be attached. This will be in accordance with the relevant installation code of practice and will ensure that any ingress protection and restricted breathing sealing requirements are maintained.
4. The threaded entry component threads without interface O-ring seals installed in an explosive dust atmosphere, within threaded entries, shall only be fitted into enclosures that have either:
 - parallel entries that will ensure that a minimum of 5 full threads of contact will be maintained, this is in accordance with clause 5.1.2 of EN 60079-31:2014
 - tapered entries that will ensure that a minimum of 3 ½ full threads of contact will be maintained, this is in accordance with clause 5.1.2 of EN 60079-31:2014
5. Cable glands with sizes 16S, 20S and 20 shall not be used for Group I, EPL Mb applications where there is a 'high' risk of mechanical damage.