

**EC2-S\*F / EC2-S\*M Eclipse Compound-Filled Conduit Stopper Box – ASSEMBLY INSTRUCTIONS**

**Brief Description**

The Peppers EC2-S\*F and EC2-S\*M compound filled type Conduit Stopper Box is for outdoor use in the appropriate Hazardous Areas with conductors carried in conduit, providing a flameproof barrier entry into enclosures and as a line bushing for terminating flying leads or for the direct inter-connection of associated enclosures. It gives environmental protection to IP66, IP68 (100 metres for 7 days), IP69 and Deluge.

**Warning**

Please read these instructions carefully. These products should not be used in applications except as detailed here or in our datasheets, unless confirmed in writing by Peppers. Peppers take no responsibility for any damage, injury or other consequential loss caused where products are not installed or used according to these instructions. This leaflet is not intended to advice on the selection of product. Further guidance can be found in the standards listed overleaf or the prevailing code of practice. The compound used within this cable gland has application limitations and may be adversely affected by some solvent vapours. If such vapours are likely to be present when the cable gland is in service, necessary precautions should be taken. Peppers Technical Datasheet can be downloaded from our website for further guidance. Prior to use the compound should be stored in a dry area at temperatures between 5°C and 30°C.

**STEP-BY-STEP FITTING INSTRUCTIONS**

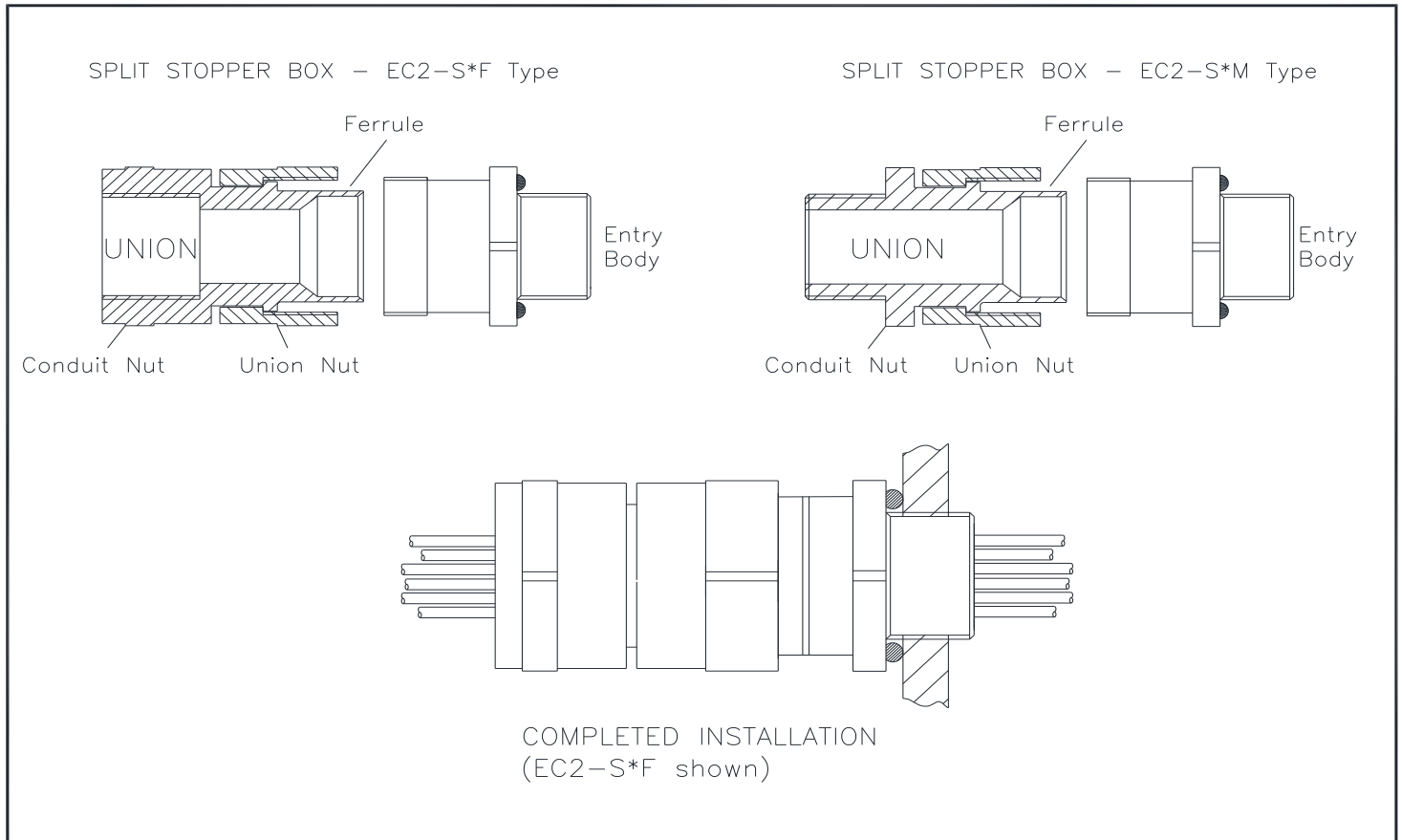

**STEP-BY-STEP FITTING INSTRUCTIONS**

- 1 Split Stopper Box as shown. Put cotton filling to one side. **Warning.** The entry body of this cable gland is coated with a releasing agent to ensure the compound form can be inspected after curing. The entry body should not be treated with any lubricant or be exposed to any solvents. The internal bore of the entry body must not be damaged. Any handling during the course of normal installation will not affect the operation of the releasing agent.
- 2 Slide Union Assembly onto cable as shown.
- 3 For EC2-S\*F glands apply suitable seal / sealant to conduit threads to maintain ingress protection. Screw Union onto conduit. For both EC2-S\*F and EC2-S\*M glands - prepare the conductors to suit the installation and pass through the union assembly.
- 4 Pack cotton filling around the cable and push inside front of Ferrule ensuring taper section is clear. Note, the cotton filling should fill any gaps between the cable sheath and the metal component to prevent the compound from travelling past the cable when injected. This will ensure a full fill and correct form, see Figure 2.
- 5 Engage Union assembly into Entry Body. Rotate Rear Assembly 7 full turns.

**HEALTH AND SAFETY WARNING** The compound can cause eye and skin irritation. For your personal protection, wear the gloves supplied whilst in contact with the compound. **A COMPREHENSIVE SAFETY DATA SHEET IS AVAILABLE FOR DOWNLOAD FROM OUR WEBSITE.**

- 6 Check compound has not passed its "Use By" date. Remove cap from cartridge and assemble nozzle.
- 7 Push plunger and dispense a small amount of compound to fill the nozzle. This clears the nozzle of air. **Failure to do so can affect cure.**
- 8 Support the cable and rear gland assembly. Hold the cable roughly concentric. Splay out the cores. Starting at the middle, inject the compound between the cores approximately halfway up internal bore. Re-straighten the cores and bundle with cord or tape (see Figure 1) so they are not disturbed. Continue to inject the compound around the outer cores to just below the Entry Body face. Where cable has large quantity of cores ensure they are bundled near to the gland entry thread to allow withdrawal after cure.
- 9 Clean off any excess compound from Entry Body thread if overfill has occurred before compound cures. Compound will cure from 60 minutes @ 23°C (68°F).
- 10 Before releasing for inspection test the edge of the compound to confirm no longer tacky. Compound must be hard and non-tacky before release is for inspection is performed.
- 11 To release and pull back the joint for inspection, unscrew Union Nut and pull away from the entry body. This will release the compound from the entry body. Do not over rotate as this may damage cable conductors. Pull the Ferrule and compound out for inspection. The compound should appear as in Figure 2 with no gaps, holes or cracks.
- 12 To re-make the joint on an EC2-S\*F gland installation hold Conduit Nut and hand-tighten Union Nut. Then refer to table below and tighten using wrench to the given amount. To re-make the joint on an EC2-S\*M gland installation screw the Union Nut into 2<sup>nd</sup> enclosure/equipment. Hand-tighten, then suitably secure with a wrench. Hold Conduit Nut and hand-tighten Union Nut. Then refer to Table 2 below and tighten using wrench to the given amount.
- 13 Fit Entry Body. For Entry Body installation torque for O-rings please refer to Table 2. Tapered threads shall be made up wrench tight. Further guidance can be found in Peppers document CT0030 which can be found on our website. The equipment can now be energised.

**EC2-S\*F / EC2-S\*M Eclipse Compound-Filled Conduit Stopper Box – ASSEMBLY INSTRUCTIONS**

Figure 1

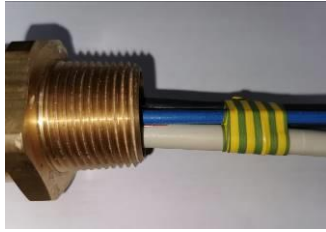

Figure 2



Table 2. Tightening information (Instruction 12), and permitted cores

Stopper Box Size	Entry Body Tightening Torque Point 13	Tighten Union Nut using wrench up to	Inner Sheath Min	Maximum Cable Size	Max Diameter Over Cores	Max No. of Cores
16S	5Nm	½-turn	4.0	10.0	8.9	12
20	5Nm	½-turn	4.0	14.0	12.5	20
25	5Nm	½-turn	8.0	18.5	16.5	30
32	5Nm	½-turn	14.0	26.3	23.5	50
40	5Nm	½-turn	16.0	32.2	28.8	65
50S	10Nm	½-turn	20.0	38.2	34.2	100
50	10Nm	½-turn	20.0	44.1	39.4	100
63S	10Nm	½-turn	30.0	50.1	44.8	130
63	10Nm	½-turn	30.0	56.0	50.0	130

**Approvals and Certification**

Approval	Certificate Number	Protection Concept / Type
ATEX	CML 19ATEX1113X / CML 21UKEX1036X	Ex I M2 II 1D 2G Ex db I Mb / Ex db IIC Gb / Ex eb I Mb / Ex eb IIC Gb / Ex ta IIIC Da
UKCA (SI 2016 No. 1107)	CML 19ATEX4114X / CML 21UKEX4037X	Ex II 3G Ex nR IIC Gc
IECEX	IECEX CML 19.0035X	Ex db I Mb / Ex db IIC Gb / Ex eb I Mb / Ex eb IIC Gb / Ex ta IIIC Da / Ex nR IIC Gc
CCC	2022312313000470	Ex d I Mb / Ex d IIC Gb / Ex e I Mb / Ex e IIC Gb / Ex nR IIC Gc / Ex tD A20 IP66
CCoE / PESO	P494321/17 & P494321/20	Ex db I Mb / Ex db IIC Gb / Ex eb I Mb / Ex eb IIC Gb / Ex nR IIC Gc
Lloyd's Register	LR2124442TA	Ex db I Mb / Ex db IIC Gb / Ex eb I Mb / Ex eb IIC Gb / Ex ta IIIC Da / Ex nR IIC Gc

**Installation Guidance**

Point	Advice
1	EN/IEC 60079-10 EN/IEC 60079-14
2	Installation should only be carried out by a competent electrician, skilled in cable gland installation.
3	Comprehensive details of the compliance standards can be found on the product certificates which are available for download from our website
4	<b>NO INSTALLATION SHOULD BE CARRIED OUT UNDER LIVE CONDITIONS.</b>
5	Threaded entries: the product can be installed directly into threaded entries. Threaded entries should comply with the relevant applicable standards and have a lead-in chamfer to allow for full engagement of the threads. Failure to provide a sufficient lead-in chamfer may lead to ingress sealing issues. For Ex db applications a minimum of 5 fully engaged parallel threads is required. Metric threads are supplied with an o-ring and will maintain IP66 and IP68. Other parallel entry threads will maintain an IP rating of IP64. A Peppers sealing washer should be used to maintain all IP ratings greater than IP64. Whilst Peppers products with tapered threads, when installed into a threaded entry, have been tested to maintain IP66 without any additional sealant, due to the differing gauging tolerances associated with the use of tapered threads it is recommended to use a non-hardening thread sealant if an IP rating higher than IP64 is required.
6	To maintain the Ingress Protection rating of the product, the entry hole must be perpendicular to the surface of the enclosure. The surface should be sufficiently flat and rigid to support the assembly and make the IP joint. The surface must be clean and dry. The product incorporates a thread run out according to general machining techniques and will not have a full form thread for the entire length and as such entry threads should have a suitable lead-in chamfer to ensure a seal is maintained. Further guidance can be found on Peppers website. It is the user's/installer's responsibility to ensure that the interface between the enclosure and cable gland is suitably sealed for the required application. Any thread sealant used shall be suitable for use in hazardous area locations, be suitable for the temperature range at the point of mounting, shall not contain evaporating solvent and cannot cause corrosion at the threaded interface when used for dissimilar materials.
7	Where a bonding connection to earth is required a Peppers earth tag should be used. Peppers earth tags have been independently tested to comply with the Category B values given in IEC 62444. Further guidance can be found on Peppers website. Peppers earth tags should be fitted over the external entry thread from either inside or outside the enclosure. If fitted internally they must be secured with a Peppers locknut and optionally a Peppers serrated washer.
8	Peppers external metric entry threads comply with ISO 965-1 and ISO 965-3 with a 6g tolerance fit. Peppers standard metric thread pitch is 1.5mm for threads up to M75 and 2.0mm for size M80 and above. Alternative thread pitches are available upon request. Peppers external NPT threads are in accordance with ASME B1.20.1 with gauging to clause 8.1. All threads comply with the threaded joint requirements of clause 5.3 from IEC 60079-1. Information on other thread types can be found in the product certificates.
9	Once installed do not dismantle except for routine inspection. An inspection should be conducted as per IEC/EN 60079-17. After inspection the gland should be re-assembled as instructed, ensuring the mid cap and back nut are correctly tightened to ensure the cable is secure.
10	The o-ring that is fitted to the outer diameter of the Ferrule (visible on figure 2) is to prevent compound from travelling inside the gland during the assembly process. It has no other function and does not contribute to the protection concept or ingress protection rating of the cable gland.
11	If required an anti-seize lubricant may be used to aid assembly and routine inspection. The lubricant should comply with the prevailing code of practice and care should be taken to ensure no lubricant comes into contact with the cable gland seals as this may impair performance.
12	For chemical resistance information please refer to Peppers T2000 Compound data sheet. Available on request.

**Interpretation of Markings.** Markings on the outside of this gland carry the following meanings:

**Cable Gland Type & Size EC2-S-a-b-ccc-ddd-eee-nn; where: -**

a =	Main component material B = brass S = stainless steel	ddd =	Entry thread type and size
b =	Back End Configuration F = female M = male	eee =	Back End Connection Thread type and size
ccc =	Gland size	nn =	Year of manufacture

**Special Conditions for Safe Use**

- The cable glands/stopper boxes shall not be used in enclosures where the temperature, at the point of entry/mounting, is outside of the range of -60°C to +120°C for Peppers T2000 Compound.
- The interface seals comply with the requirements of the standards listed in this report when the cable glands are fitted to a representative enclosure having a smooth flat mounting surface. In practice the interface between the male thread of the glands and their associated enclosure cannot be defined, therefore it is the users' responsibility to ensure that the appropriate ingress protection level is maintained at these interfaces.
- The parallel threaded entry component threads will be suitably sealed using a method that is applicable to the associated equipment to which the gland will be attached. This will be in accordance with the relevant installation code of practice and will ensure that any ingress protection and restricted breathing sealing requirements are maintained.
- The threaded entry component threads without interface O-ring seals installed in an explosive dust atmosphere, within threaded entries, shall only be fitted into enclosures that have either:
  - parallel entries that will ensure that a minimum of 5 full threads of contact will be maintained, this is in accordance with clause 5.1.2 of EN 60079-31:2014
  - tapered entries that will ensure that a minimum of 3 ½ full threads of contact will be maintained, this is in accordance with clause 5.1.2 of EN 60079-31:2014
- Cable glands with sizes 16S, 20S and 20 shall not be used for Group I, EPL Mb applications where there is a 'high' risk of mechanical damage.