

A8RC** Type Cable Glands for Flat Cable – ASSEMBLY INSTRUCTIONS

Brief Description

Peppers A8RC** range of cable glands are for use in the appropriate Hazardous Areas with flat/heat trace cable. These cable glands give environmental protection to IP66/67/68 (50 metres for 7 days). The A8RC** range of cable glands are for use only with appropriate plain or sheathed wound flexible metallic conduit.

Warning

Please read these instructions carefully. These products should not be used in applications except as detailed here or in our datasheets, unless confirmed in writing by Peppers. Peppers take no responsibility for any damage, injury or other consequential loss caused where products are not installed or used according to these instructions. This leaflet is not intended to advise on the selection of product. Further guidance can be found in the standards listed overleaf or the prevailing code of practice.

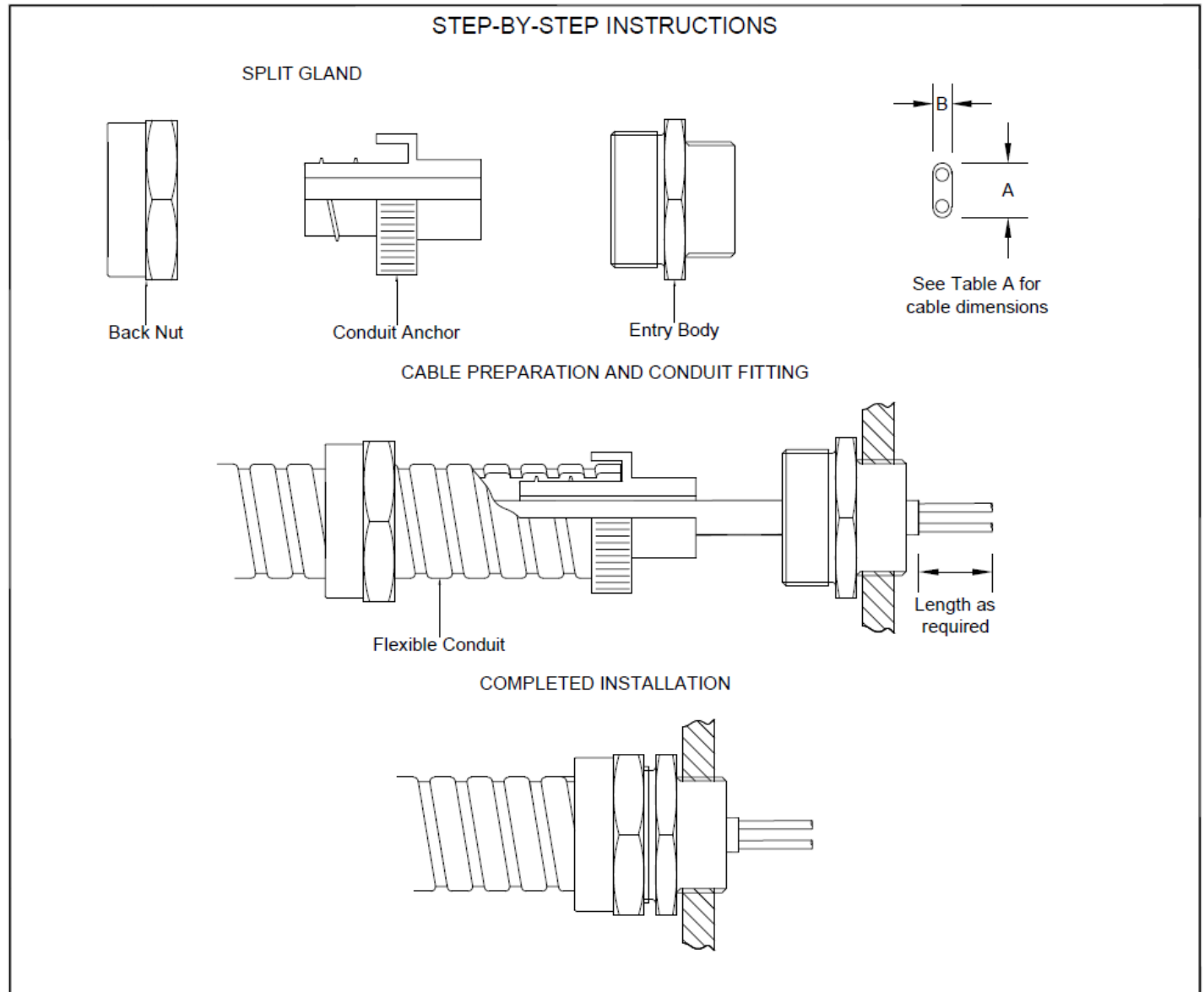

STEP-BY-STEP FITTING INSTRUCTIONS

1. Split the gland as shown, remove the Back Nut and Conduit Anchor from the Entry Body. There is no need to remove the inner seal or skid washer (size 20R only) from the entry body.
2. Fit Entry Body, allowing for any installation accessories, and fully engage the thread into the equipment. Hand-tighten, then suitably secure with a wrench. Further guidance can be found in Peppers document CT0030 which can be found on our website.
3. Prepare cable as required. Bring the cable through the flexible conduit and Conduit Anchor.
4. Slide the Back Nut over the flexible conduit. Thread the Conduit Anchor into the flexible conduit until it is fully engaged.
5. Insert cable through the entry body, locate the Conduit Anchor into the Entry Body recess and engage the Back Nut on to the Entry Body.
6. Position the cable correctly. The seal must grip the outer jacket of the cable when the cable gland is tightened.
7. Tighten Back Nut to Entry Body. Ensure the seal makes full contact with cable sheath and then tighten the Back Nut by the additional turns/torque (whichever is greater) as detailed below in Table A.

Table A - Cable & Conduit Size Acceptance Data (mm)

Gland size	Cable Sheath Dimensions (see Diagram)				Conduit Dimensions		Back Nut Assembly – Step 7	
	Min.	Max.	Min.	Max.	Typical Conduit I/D	Max. Conduit O/D	Torque	Turns
20S-1	6.3	11.2	4.0	7.0	13.0	18.0	5 Nm	1
20S-2	6.3	11.7	4.0	7.0	13.9	19.5	5 Nm	1
20S-3	6.3	11.7	4.0	7.0	16.9	22.0	5 Nm	1
20-1	10.3	11.2	5.6	9.0	13.0	18.0	5 Nm	1
20-2	10.3	13.5	5.6	9.0	13.9	19.5	5 Nm	1
20-3	10.3	13.5	5.6	9.0	16.9	22.0	5 Nm	1
20R-1	8.1	11.2	5.8	6.2	13.0	18.0	5 Nm	1
20R-2	8.1	13.5	5.8	6.2	13.9	19.5	5 Nm	1
20R-3	8.1	13.5	5.8	6.2	16.9	22.0	5 Nm	1
25-1	10.6	16.2	4.0	7.0	16.9	23.8	15 Nm	1 ½
25-2	10.6	16.2	4.0	7.0	18.7	24.8	15 Nm	1 ½
25-3	10.6	16.2	4.0	7.0	21.1	26.8	15 Nm	1 ½
25-4	10.6	16.2	4.0	7.0	20.7	27.8	15 Nm	1 ½

A8RC** Type Cable Glands for Flat Cable – ASSEMBLY INSTRUCTIONS

Approvals & Certification

Approval	Certificate Number	Protection Concept / Type
ATEX (2014/34/EU)	CML 19ATEX1346X / CML 21UKEX1033X	II 1D 2G Ex db IIC Gb / Ex eb IIC Gb / Ex ta IIIC Da
UKCA (SI 2016 No. 1107)	CML 19ATEX4109X / CML 21UKEX4043X	II 3G Ex nR IIC Gc
IECEX	IECEX CML 19.0104X	Ex db IIC Gb / Ex eb IIC Gb / Ex nR IIC Gc / Ex ta IIIC Da
INMETRO	NCC 13.2187X	Ex db IIC Gb / Ex eb IIC Gb / Ex nR IIC Gc / Ex ta IIIC Da
EAC	ПРОММАН ТЕКТ RU C-GB.АЖ58.В.05106	1Ex db IIC Gb X / 1Ex eb IIC Gb X / 2Ex nR IIC Gc X / Ex ta IIIC Da X
UKRAINE	CU 18.0321 X	II 1D 2G 3G Ex db IIC Gb / Ex eb IIC Gb / Ex nR IIC Gc / Ex ta IIIC Da
CCC	2021312313000447	Ex db IIC Gb / Ex eb IIC Gb / Ex nR IIC Gc / Ex ta IIIC Da IP66
CCoE (PESO)	P494321/7 & P494321/13	Ex db IIC Gb / Ex eb IIC Gb / Ex ta IIIC Da / Ex nR IIC Gc
ABS	20-LD1944057-PDA	Specified ABS Rules – See certificate
Lloyd's Register	LR2124442TA	Ex db IIC Gb / Ex eb IIC Gb / Ex nR IIC Gc / Ex ta IIIC Da
DNV	TAE00004XK	Ex db IIC Gb / Ex eb IIC Gb / Ex nR IIC Gc / Ex ta IIIC Da

Installation Guidance

Point	Advice
1	BS/EN/IEC 60079-10
2	BS/EN/IEC 60079-14
3	Installation should only be carried out by a competent electrician, skilled in cable gland and appropriate electrical installations.
4	Comprehensive details of the compliance standards can be found in the product certificates which are available for download from our website.
5	NO INSTALLATION SHOULD BE CARRIED OUT UNDER LIVE CONDITIONS.
6	Threaded entries: the product can be installed directly into threaded entries. Threaded entries should comply with the relevant applicable standards and have a lead-in chamfer to allow for full engagement of the threads. Failure to provide a sufficient lead-in chamfer may lead to ingress sealing issues. For Ex db applications a minimum of 5 fully engaged threads is required.
7	Clearance holes: these shall be no larger than 0.7mm above the nominal diameter of the external entry thread. The product should be secured with a Peppers locknut and then tightened to ensure the cable gland is secure. Where no integral sealing method is provided a Peppers sealing washer should be used to maintain IP ratings. A Peppers serrated washer should be used for additional installation protection. Peppers does not recommend using tapered threads in clearance holes.
8	Ingress protection: to maintain the Ingress Protection rating of the product, the entry hole must be perpendicular to the surface of the enclosure. The surface should be clean, dry and must be sufficiently flat and rigid to support the assembly and make the IP joint. Metric threads are supplied with an O-ring and will maintain IP66. Other parallel entry threads will maintain an IP rating of IP64. A Peppers sealing washer should be used to maintain all IP ratings greater than IP64. Whilst Peppers products with tapered threads, when installed into a threaded entry, have been tested to maintain IP66 without any additional sealant, due to the differing gauging tolerances associated with the use of tapered threads it is recommended to use a non-hardening thread sealant if an IP rating higher than IP64 is required. Any thread sealant used should be suitable for use in the hazardous area or location where the equipment is installed, have a suitable temperature range for the temperature at the point of mounting, not contain evaporating solvents and not cause corrosion at the threaded interface when used with dissimilar materials. The product incorporates a thread run out according to general machining techniques and will not have a full form thread for the entire length. Threaded entries should have a suitable lead-in chamfer to ensure a seal is maintained, further guidance can be found on Peppers website. It is the user's/installer's responsibility to ensure that the interface between the enclosure and cable gland is suitably sealed for the required application.
9	Where a bonding connection to earth is required a Peppers earth tag should be used. Peppers earth tags have been independently tested to comply with the Category B values given in IEC 62444. Peppers earth tags should be fitted over the external entry thread from either inside or outside the enclosure. If fitted internally they must be secured with a Peppers locknut and optionally a Peppers serrated washer. Further guidance can be found in Peppers document CT0170 which can be found on our website.
10	Peppers external metric entry threads comply with ISO 965-1 & ISO 965-3 with a 6g tolerance fit. The standard metric thread pitch is 1.5mm for threads up to M75 and 2.0mm for size M80 and above. Alternative thread pitches are available upon request. Peppers external NPT threads comply with ASME B1.20.1 with gauging to clause 8.1. All threads comply with the threaded joint requirements of clause 5.3 from IEC 60079-1. Information on other thread types can be found in the product certificates.
11	Once installed do not dismantle except for routine inspection. An inspection should be conducted as per IEC 60079-17. After inspection the gland should be re-assembled as instructed, ensuring the compression nut, mid cap and back nut are correctly tightened to ensure the cable is secure.
12	If required an anti-seize lubricant may be used to aid assembly and routine inspection, if used care should be taken to ensure no lubricant comes into contact with the cable gland seals as this may impair performance. Any lubricant used should comply with the prevailing code of practice, be suitable for use in the hazardous area or location where the equipment is installed, have a suitable temperature range and not contain evaporating solvents.

Interpretation of Markings

Markings on the outside of this gland carry the following meanings:

Cable Gland Type & Size A8RC-a-b-ccc-ddd-nn

a =	Main component material	B = Brass	ccc =	Gland size
		S = Stainless Steel	ddd =	Entry thread type and size
b =	Protection Concept	F = Ex db	nn =	Year of manufacture
		E = Ex eb		

Specific Conditions of Use

- A8RC** glands must not be used in enclosures where the temperature at the point of contact is outside the range of -60°C to +180°C.
- A8RC** cable glands shall only be used for fixed installations, in addition the cables must be effectively clamped to prevent pulling or twisting.
- When installed in accordance with these instructions within appropriate equipment, A8RC** glands are capable of providing an ingress protection of IP66 and IP68 (50 metres - 7 days).
- When used in explosive dust atmospheres and installed in threaded entries without interface O-ring seals, A8RC** glands shall only be fitted into enclosures that have either:
 - parallel entries that will ensure a minimum of 5 full threads of contact will be maintained, this is in accordance with clause 5.1.2 of IEC 60079-31.
 - tapered entries that will ensure a minimum of 3 ½ full threads of contact will be maintained, this is in accordance with clause 5.1.2 of IEC 60079-31.