

CR-C*** (inc. CX-C**) Compound-Filled Cable Glands featuring CROCLOCK® - ASSEMBLY INSTRUCTIONS

Brief Description

Peppers CR-C*** type Compound-filled cable glands featuring CROCLOCK® universal armour clamping are for outdoor use in appropriate Hazardous Areas with circular pliable wire/ steel wire/ steel tape armoured, braided, screened and unarmoured cable. A variant giving electrical continuity to a lead sheath is available. They give environmental protection to IP66 & IP68 (100 metres for 7 days) and Deluge. A termination suitable for EMC protection can be made using armoured cables with this gland.

Warning

Please read these instructions carefully. These products should not be used in applications except as detailed here or in our datasheets, unless confirmed in writing by Peppers. Peppers take no responsibility for any damage, injury or other consequential loss caused where products are not installed or used according to these instructions. This leaflet is not intended to advise on the selection of product. Further guidance can be found in the standards listed overleaf or the prevailing code of practice. The compound used within this cable gland has application limitations and may be adversely affected by some solvent vapours. If such vapours are likely to be present when the cable gland is in service, necessary precautions should be taken. Peppers Technical Datasheet can be downloaded from our website for further guidance. Prior to use the compound should be stored in its original packaging in a dry area at temperatures between 5°C and 21°C.

STEP-BY-STEP INSTRUCTIONS

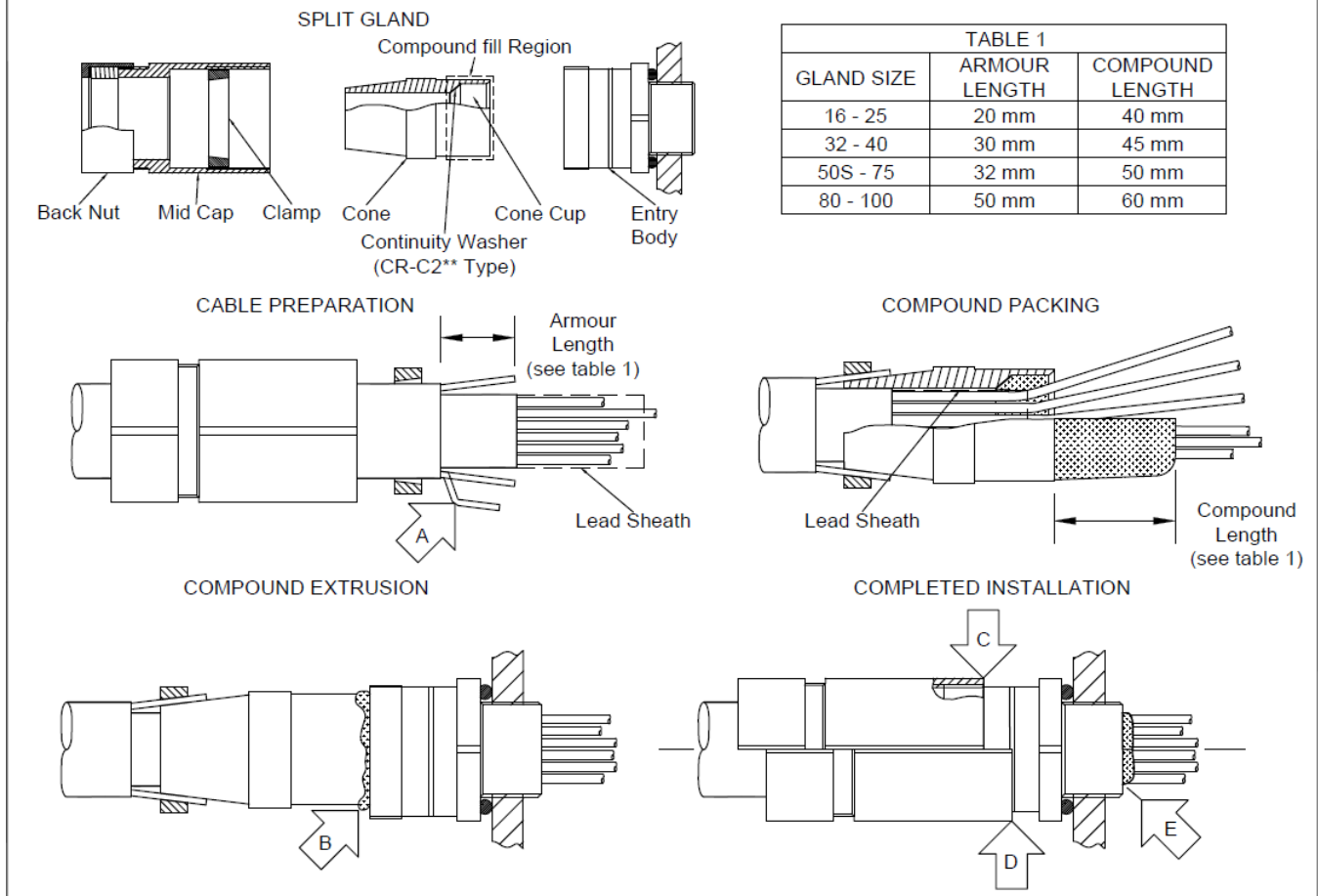

STEP-BY-STEP FITTING INSTRUCTIONS

- Split the gland as shown. Warning - the entry body of this cable gland is coated with a releasing agent to ensure the compound form can be inspected after curing. The entry body should not be treated with any lubricant or be exposed to any solvents. The internal bore of the entry body must not be damaged. Any handling during the course of normal installation will not affect the operation of the releasing agent.
- Fit Entry Body, allowing for any installation accessories, and fully engage the entry thread into the equipment. Hand-tighten, then suitably secure with a wrench. Further guidance can be found in Peppers document CT0030 which can be found on our website.
- Slide Back Nut, Mid Cap and Clamp onto cable as shown.
- CABLE PREPARATION** Strip off outer jacket, to a length to suit the installation.
 - For armoured cable:-
 - A. Cut armour. For approximate exposed lengths see Table 1.
 - B. Where sheath sizes are near minimum, wire armour may require forming to facilitate clamping (arrow A).
 - For all cables:-
 - C. Remove inner sheath to a length to suit the installation. Lead sheath must be cut to push through the continuity washer. Remove protective foils and any cords/fillers from around and between the cores. Take care not to cut insulating sleeves of the cores. Pigtail and sleeve screens to be passed through compound.
- Slide the Cone onto inner sheath and under armour. For lead sheath cable push through the continuity washer ensuring contact is made. Slide the Clamp over the exposed armour.
- Insert the cable through the Entry Body to engage the Cone. Push cable forward to maintain armour contact.
- To clamp armour onto Cone, hand-tighten the Mid Cap to Entry Body then using wrench tighten an additional one turn. Cable with maximum diameter wire armour may require an additional half to one turn.
- UnscREW Mid Cap to visually check armour is securely clamped. Pull out cable and Cone. If armour has not clamped repeat the clamping process.

HEALTH AND SAFETY WARNING: The resin used in the compound can cause eye and skin irritation. For your personal protection, wear the gloves supplied whilst in contact with the compound. **A COMPREHENSIVE SAFETY DATA SHEET IS AVAILABLE FOR DOWNLOAD FROM OUR WEBSITE.**
- Check compound has not passed its "Use By" date. It has a work life of about 30 minutes at 16-27°C (60-80°F), during which time it can be worked and shaped before it begins to cure. Full cure takes 24 hours at 16-27°C (60-80°F). Lower temperatures will give a longer cure time. E.g. at 3°C (37°F) full cure takes about seven days. It is recommended to mix the putty and pack the fitting at 20°C (68°F). Minimum mixing/packing temperature is 10°C. Minimum curing temperature is 3°C.
- Mix the compound by rolling, folding and breaking. Ease mixing by cutting large sticks in half. Fully mixed compound has a uniform colour with no streaks See Figure 1 for correctly mixed compound.
- Support the cable and rear gland assembly. With unarmoured cable, hold the Cone and cable roughly concentric. Splay out the cores. Starting in the middle, pack small amounts of rolled-out compound between the cores. Re-straighten each core and work outwards until all gaps are filled. Bundle the cores with cord or tape (see Figure 2) so they are not disturbed. Pack around the outside of the cores to fill the Cone Cup. Build up compound around the outside of the cores with a slight taper and to an approximate compound length shown in the diagram and Table 1. Where the cable has large a quantity of cores ensure they are bundled near to the gland entry thread.
- Pass the cores through & push compound into Entry Body until Cone engages. Remove squeezed out compound at arrow B. For thickest armour: Screw Mid Cap seven full turns onto the Entry Body (arrow C). For tape armours/braids: screw no further than the groove (sizes 16 & 20S: screw no closer than 6mm [1/4 inch] from Entry Body hexagon) (arrow D). Ensure that compound emerges at entry thread (arrow E).
- Clean excess compound from Entry Body to allow withdrawal when cured (arrow E), cores may be disturbed after 1 hour, leave to cure for 4 hours when working at 21°C.
- To release the compound for inspection unscREW the Mid Cap. Using a wrench on the Cone, rotate the Cone back and forth whilst pulling the rear assembly away from the entry body. This will release the compound from the entry body. Do not over rotate as this may damage cable cores or braid. Pull the cone and compound out for inspection. The compound should appear as in Figure 3 with no gaps, holes or cracks.
- Hand-tighten the Mid Cap to remake joint. Then tighten using a wrench by the additional turns in table 2.
- Hold the Mid Cap with a wrench and tighten Back Nut onto cable. Ensure the seal makes full contact with the cable sheath, and then tighten Back Nut one extra turn.
- The equipment should not be energised until the compound has been left to cure for at least 4 hours when working at 21°C. See chart 'Compound Cure Time vs. Temperature' for further guidance.

CR-C* (inc. CX-C**) Compound-Filled Cable Glands featuring CROCKLOCK® - ASSEMBLY INSTRUCTIONS**

Figure 1.



Figure 2

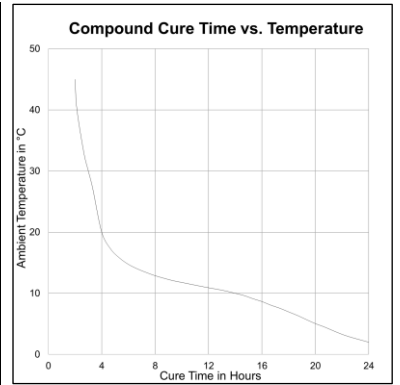

Figure 3



Table 2 – Installation Data, Cable Sizes and Armour Acceptance (mm)

Gland Size	Tighten Mid Cap With Wrench	Max. Ø Over Cores	Max. No. of Cores	Max Inner Sheath	Outer Sheath		Reduced Bore		Armour Size, All	
					Max.	Min.	Max.	Min.	Max.	Min.
16	½-turn	10.4	15	11.7	8.4	13.5	6.7	10.3	0.15	1.25
20S	½-turn	10.4	35	11.7	11.5	16.0	9.4	12.5	0.15	1.25
20	½-turn	12.5	40	14.0	15.5	21.1	12.0	17.6	0.15	1.25
25	½-turn	17.8	60	20.0	20.3	27.4	16.8	23.9	0.15	1.6
32	½-turn	23.5	80	26.3	26.7	34.0	23.2	30.5	0.15	2.0
40	½-turn	28.8	130	32.2	33.0	40.6	28.6	36.2	0.2	2.0
50S	½-turn	34.2	200	38.2	39.4	46.7	34.8	42.4	0.2	2.5
50	½-turn	39.4	400	44.1	45.7	53.2	41.1	48.5	0.2	2.5
63S	½-turn	44.8	400	50.1	52.1	59.5	47.5	54.8	0.3	2.5
63	½-turn	50.0	425	56.0	58.4	65.8	53.8	61.2	0.3	2.5
75S	½-turn	55.4	425	62.0	64.8	72.2	60.2	68.0	0.3	2.5
75	½-turn	60.8	425	68.0	71.1	78.0	66.5	73.4	0.3	2.5
80	¾-turn	64.4	425	72.0	77.0	84.0	71.9	79.4	0.45	3.15
85	¾-turn	69.8	425	78.0	79.6	90.0	75.0	85.4	0.45	3.15
90	¾-turn	75.1	425	84.0	88.0	96.0	82.0	91.4	0.45	3.15
100	¾-turn	80.5	425	90.0	92.0	102.0	87.4	97.4	0.45	3.15



CX-C** Gland - Gland size 20S braid clamping range 0.15-0.35 mm, gland size 20 braid clamping range 0.15-0.50mm.

Approvals and Certifications

Approval	Certificate Number	Protection Concept / Type
ATEX (2014/34/EU)	CML 19ATEX1344X / CML 21UKEX1031X	Ex I M2 II 1D 2G Ex db I Mb / Ex db IIC Gb / Ex eb I Mb / Ex eb IIC Gb / Ex ta IIIC Da
UKCA (SI 2016 No. 1107)	CML 19ATEX4114X / CML 21UKEX4037X	Ex II 3G Ex nR IIC Gc
IECEX	IECEX CML 19.0046X	Ex db I Mb / Ex db IIC Gb / Ex eb I Mb / Ex eb IIC Gb / Ex nR IIC Gc / Ex ta IIIC Da
CSA	1356011	Ex db IIC Gb / Ex eb IIC Gb / Ex ta IIC Da Class I Zone 1 AEx db IIC Gb / Class I Zone 1 AEx eb IIC Gb / Zone 20 AEx ta IIIC Da CL I Div 2 Gr ABCD / CL II Gr EFG / CL III Type 4X IP66 IP68
INMETRO	NCC 13.2188 X	Ex db I Mb / Ex db IIC Gb / Ex eb I Mb / Ex eb IIC Gb / Ex nR IIC Gc / Ex ta IIIC Da
EAC	ΠΡΟΜΜΑΨ ΤΕCΤ RU C-GB.ΑΚ58.B.05106	1Ex db IIC Gb X / 1Ex eb IIC Gb X / 2Ex nR IIC Gc X / PB Ex d I Mb / Ex ta IIIC Da X
UKRAINE	CLJ 18.0322 X	I M2 Ex db I Mb / Ex eb I Mb / II 1D 2G 3G Ex db IIC Gb / Ex eb IIC Gb / Ex nR IIC Gc / Ex ta IIIC Da
CCC	2021312313000407	Ex db I Mb / Ex db IIC Gb / Ex eb I Mb / Ex eb IIC Gb / Ex nR IIC Gc / Ex ta IIIC Da IP66
CCoE (PESO)	P494321/18 & P494321/20	Ex db I Mb / Ex db IIC Gb / Ex eb I Mb / Ex eb IIC Gb / Ex nR IIC Gc
ABS	20-LD1944057-PDA14-LD463991A-1-PDA	Specified ABS Rules – See certificate
Lloyd's Register	LR2124442TA	Ex db I Mb / Ex db IIC Gb / Ex eb I Mb / Ex eb IIC Gb / Ex nR IIC Gc / Ex ta IIIC Da
DNV	TAE00004XK	Ex db I Mb / Ex db IIC Gb / Ex eb I Mb / Ex eb IIC Gb / Ex nR IIC Gc / Ex ta IIIC Da

Installation Advice

Point	Advice
1	BS/EN/IEC 60079-10 BS/EN/IEC 60079-14 National Electrical Code (NEC 500-505) Canadian Electrical Code (CSA C22.1)
2	Installation should only be carried out by a competent electrician, skilled in cable gland and appropriate electrical installations.
3	Comprehensive details of the compliance standards can be found in the product certificates which are available for download from our website.
4	NO INSTALLATION SHOULD BE CARRIED OUT UNDER LIVE CONDITIONS.
5	Threaded entries: the product can be installed directly into threaded entries. Threaded entries should comply with the relevant applicable standards and have a lead-in chamfer to allow for full engagement of the threads. Failure to provide a sufficient lead-in chamfer may lead to ingress sealing issues. For Ex db applications a minimum of 5 fully engaged threads is required.
6	Clearance holes: these shall be no larger than 0.7mm above the nominal diameter of the external entry thread. The product should be secured with a Peppers locknut and then tightened to ensure the cable gland is secure. Where no integral sealing method is provided a Peppers sealing washer should be used to maintain IP ratings. A Peppers serrated washer should be used for additional installation protection. Peppers does not recommend using tapered threads in clearance holes.
7	Ingress protection: to maintain the Ingress Protection rating of the product, the entry hole must be perpendicular to the surface of the enclosure. The surface should be clean, dry and must be sufficiently flat and rigid to support the assembly and make the IP joint. Metric threads are supplied with an O-ring and will maintain IP66 and IP68. Other parallel entry threads will maintain an IP rating of IP64. A Peppers sealing washer should be used to maintain all IP ratings greater than IP64. Whilst Peppers products with tapered threads, when installed into a threaded entry, have been tested to maintain IP66 without any additional sealant, due to the differing gauging tolerances associated with the use of tapered threads it is recommended to use a non-hardening thread sealant if an IP rating higher than IP64 is required. Any thread sealant used should be suitable for use in the hazardous area or location where the equipment is installed, have a suitable temperature range for the temperature at the point of mounting, not contain evaporating solvents and not cause corrosion at the threaded interface when used with dissimilar materials. The product incorporates a thread run out according to general machining techniques and will not have a full form thread for the entire length. Threaded entries should have a suitable lead-in chamfer to ensure a seal is maintained, further guidance can be found on Peppers website. It is the user's/installer's responsibility to ensure that the interface between the enclosure and cable gland is suitably sealed for the required application.
8	Where a bonding connection to earth is required a Peppers earth tag should be used. Peppers earth tags have been independently tested to comply with the Category B values given in IEC 62444. Peppers earth tags should be fitted over the external entry thread from either inside or outside the enclosure. If fitted internally they must be secured with a Peppers locknut and optionally a Peppers serrated washer. Further guidance can be found in Peppers document CT0170 which can be found on our website.
9	Peppers external metric entry threads comply with ISO 965-1 & ISO 965-3 with a 6g tolerance fit. The standard metric thread pitch is 1.5mm for threads up to M75 and 2.0mm for size M80 and above. Alternative thread pitches are available upon request. Peppers external NPT threads comply with ASME B1.20.1 with gauging to clause 8.1. All threads comply with the threaded joint requirements of clause 5.3 from IEC 60079-1. Information on other thread types can be found in the product certificates.
10	Once installed do not dismantle except for routine inspection. An inspection should be conducted as per IEC 60079-17. After inspection the gland should be re-assembled as instructed, ensuring the compression nut, mid cap and back nut are correctly tightened to ensure the cable is secure.
11	The O-ring that is fitted to the outer diameter of the Cone Cup (visible on figure 3) is to prevent compound from extruding inside the gland during the assembly process. It has no other function and does not contribute to the protection concept or ingress protection rating of the cable gland.
12	If required an anti-seize lubricant may be used to aid assembly and routine inspection, if used care should be taken to ensure no lubricant comes into contact with the cable gland seals as this may impair performance. Any lubricant used should comply with the prevailing code of practice, be suitable for use in the hazardous area or location where the equipment is installed, have a suitable temperature range and not contain evaporating solvents.

Interpretation of Markings

Markings on the outside of this gland have the following meanings: CR-C-2-a-R-bbb-ccc-nn.

2 =	Optional continuity washer for lead sheathed cable	bbb =	Gland size
a =	Main component material	B =	Brass
		S =	Stainless Steel
R =	Optional reduced bore outer seal (red silicone)	ccc =	Entry thread type and size
		nn =	Year of manufacture

Specific Conditions of Use

- CR-C*** glands must not be used in enclosures where the temperature at the point of contact is outside the range of -60°C to +135°C.
- The interface seals comply with the requirements of the standards listed the certificates above when CR-C*** glands are fitted to a representative enclosure having a smooth flat mounting surface. In practice the interface between the male thread of the glands and their associated enclosure cannot be defined, therefore it is the user's responsibility to ensure that the appropriate ingress protection level is maintained at these interfaces.
- When used in explosive dust atmospheres and installed in threaded entries without interface O-ring seals, CR-C*** glands shall only be fitted into enclosures that have either:
 - parallel entries that will ensure a minimum of 5 full threads of contact will be maintained, this is in accordance with clause 5.1.2 of IEC 60079-31.
 - tapered entries that will ensure a minimum of 3 ½ full threads of contact will be maintained, this is in accordance with clause 5.1.2 of IEC 60079-31.

